

LOTE Nº 1

TITULAR:	ESTADO. DELEGACIÓN DEL GOBIERNO PARA EL PLAN NACIONAL SOBRE DROGAS
Descripción:	MCA 1893/2017 - Plazas de garaje nº 1, 2 y en el callejón Loureiro, 10, planta -1. Parroquia de Barrantes, municipio Ribadumia, sito Bouza Martín, lugar de Rabunade, Pontevedra.
Inscritas en el Registro de la Propiedad:	Nº 1 Cambados, FR 10569, inscripción 5ª, tomo 1416, libro 101, folio 151. Nº 1 Cambados, FR 10570, inscripción 5ª, tomo 1520, libro 107, folio 116. Nº 1 Cambados, FR 10571, inscripción 5ª, tomo 1520, libro 107, folio 118.
Referencia Catastral:	9056513NH1095N0003ZS
Valor de Tasación:	17.815,41 €
Precio mínimo oferta:	14.253 €

CROQUIS

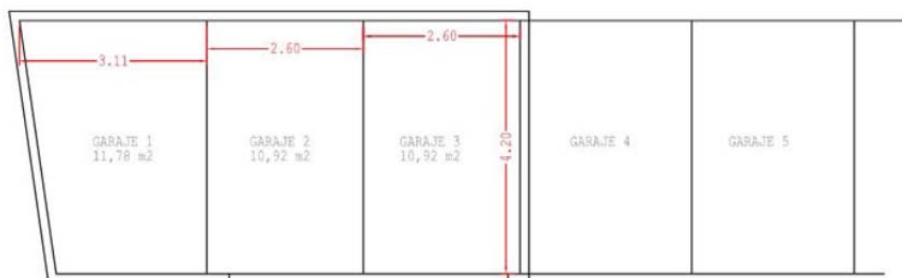

ENTORNO



ENTORNO



EXTERIOR EDIFICIO



EXTERIOR EDIFICIO



ACCESO A GARAJES



EXTERIOR PORTAL



ACCESO A PLAZAS



GARAJES 1, 2, 3



TABIQUE PLAZA 1



INTERIOR PLAZA 1



PLAZAS COLINDANTES



LOTE Nº 2

TITULAR:	ESTADO. DELEGACIÓN DEL GOBIERNO PARA EL PLAN NACIONAL SOBRE DROGAS
Descripción:	MCA 141/2011 – Plaza de garaje nº 88 en edificio en la calle Melilla, 39, sótano – 1 de Madrid
Inscrita en el Registro de la Propiedad:	Nº 13 de Madrid, FR 49914/s1p88, inscripción 1ª, tomo 2.641, libre 2.137, folio 74.
Referencia Catastral:	9926410VK3792H0447KA
Valor de Tasación:	26.419,43 €
Precio mínimo oferta:	21.136 €

EXTERIOR EDIFICIO



INTERIOR SÓTANO Y GARAJE

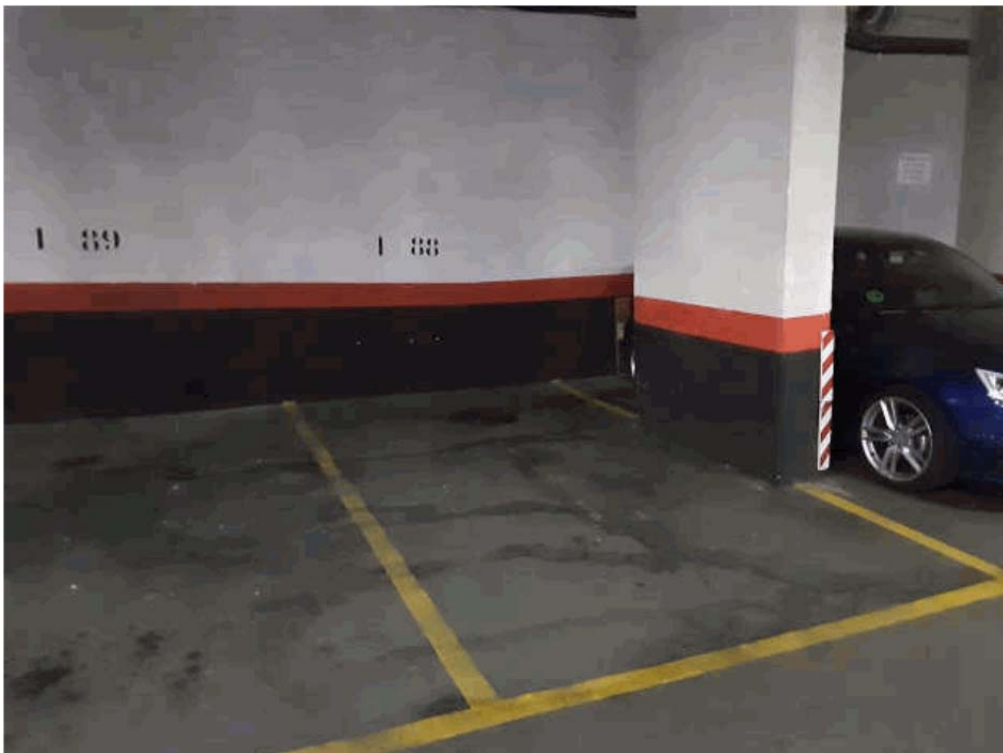
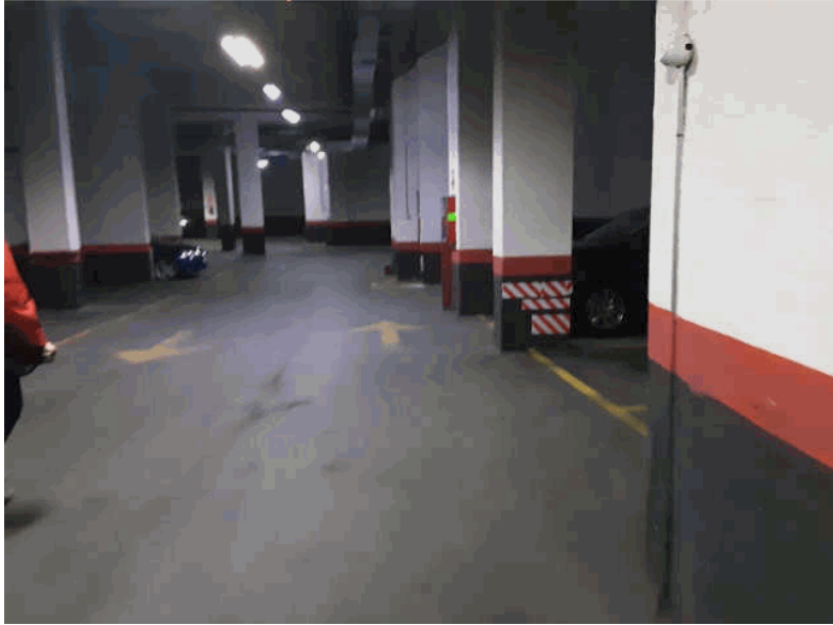

CROQUIS DE DISTRIBUCIÓN

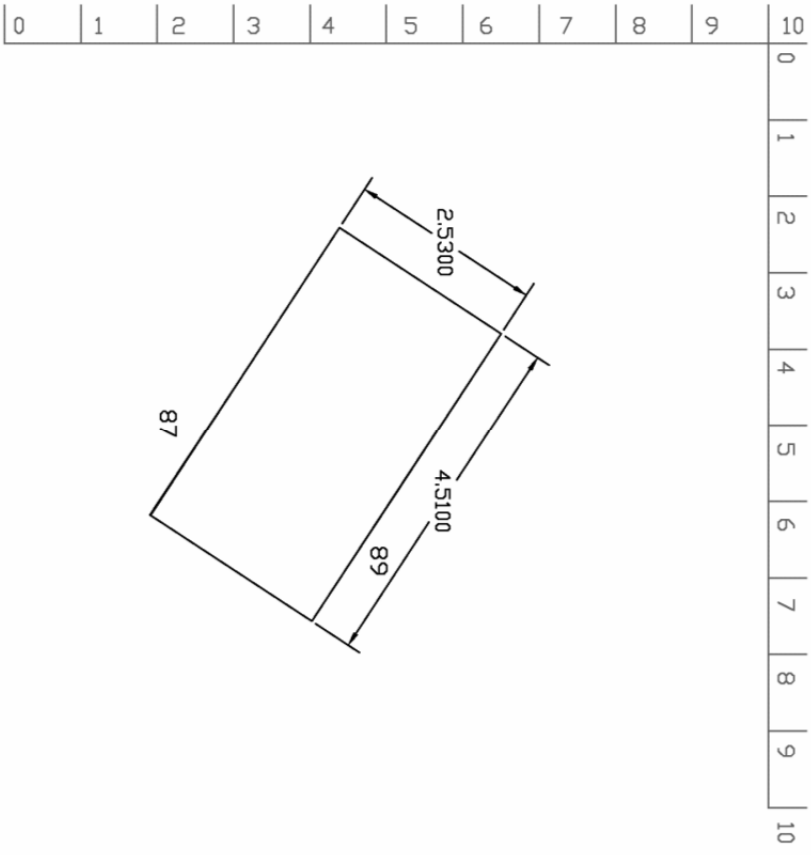

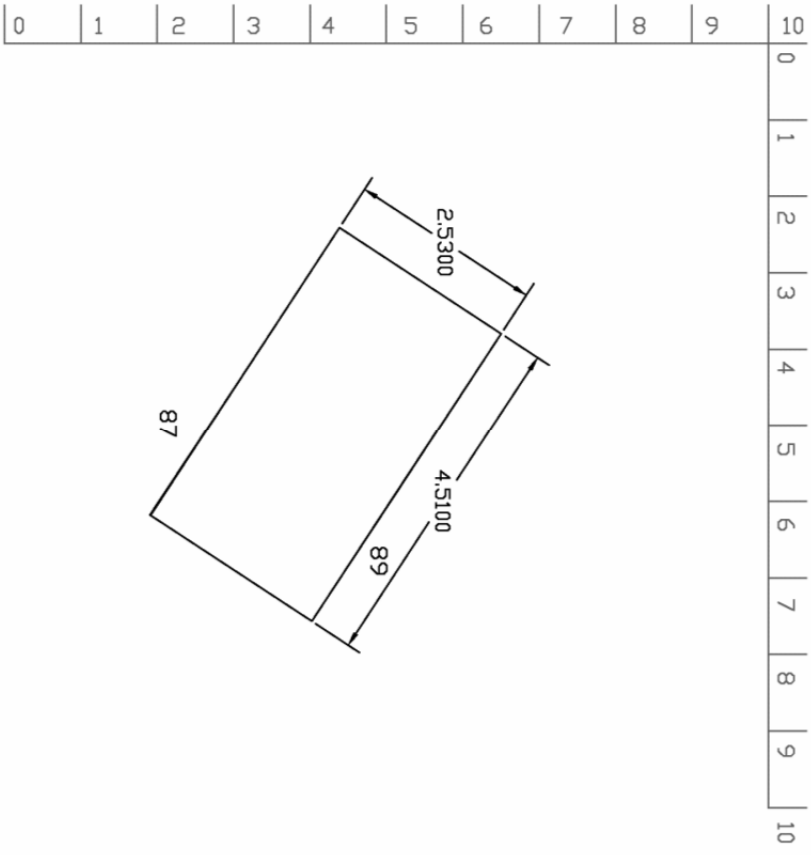

LOTE Nº 3

TITULAR:	ESTADO. DELEGACIÓN DEL GOBIERNO PARA EL PLAN NACIONAL SOBRE DROGAS
Descripción:	MCA 141/2011 – Trastero nº 83 en edificio en la calle Melilla, 39, sótano – 1 de Madrid
Inscrita en el Registro de la Propiedad:	Nº 13 de Madrid, FR 49922/T83, inscripción 1ª, tomo 2.641, libre 2.137, folio 77.
Referencia Catastral:	9926410VK3792H0553QJ
Valor de Tasación:	2.681,85 €
Precio mínimo oferta:	2.145 €

EXTERIOR



INTERIOR SÓTANO Y TRASTERO

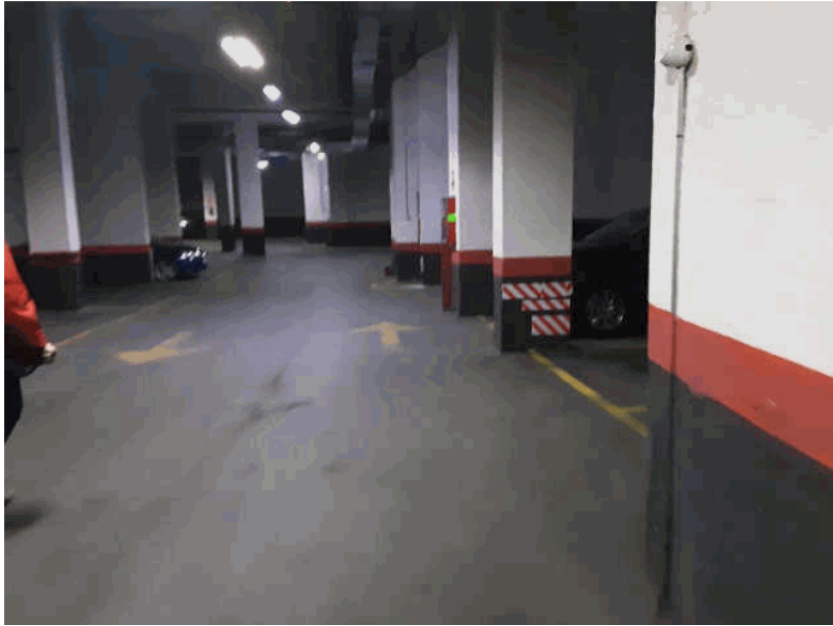

CROQUIS

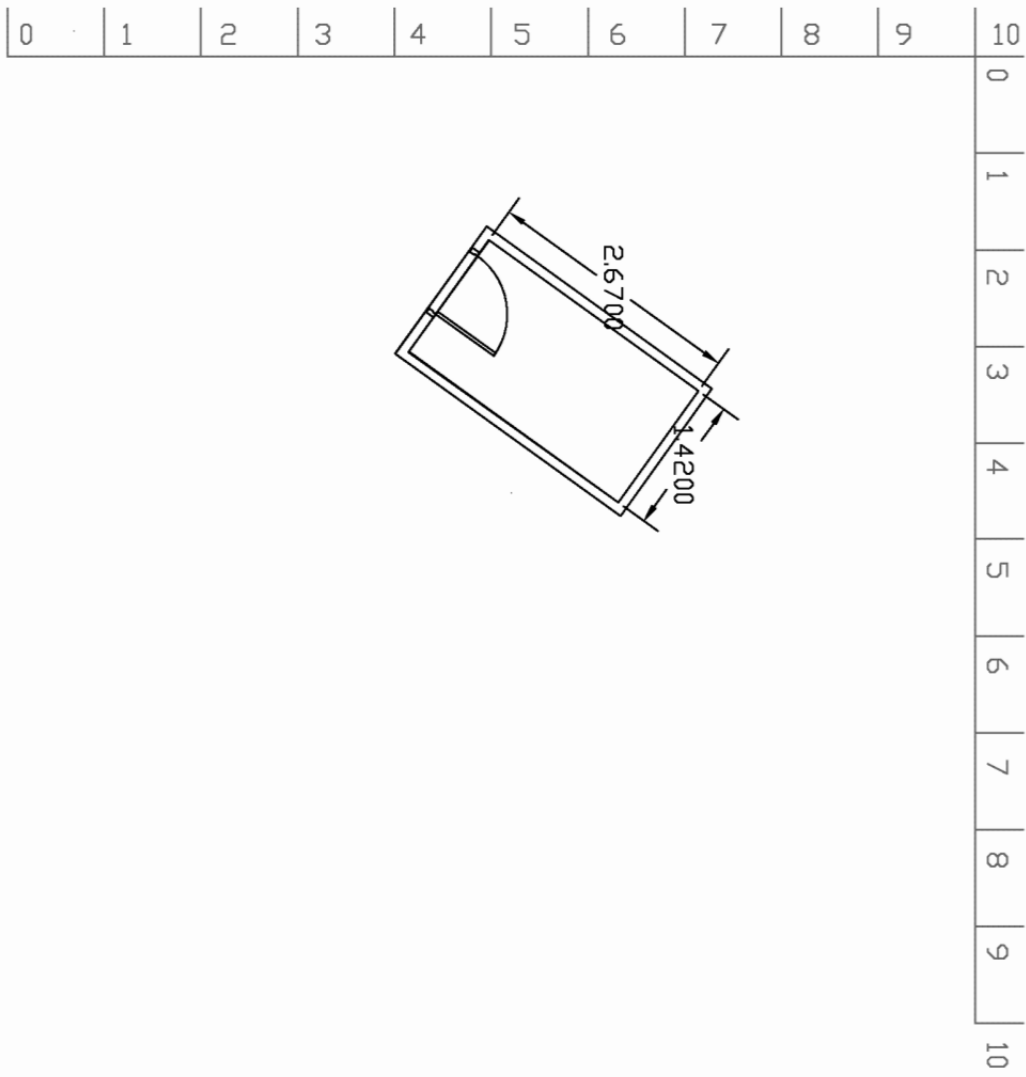

LOTE Nº 4

TITULAR:	ESTADO. DELEGACIÓN DEL GOBIERNO PARA EL PLAN NACIONAL SOBRE DROGAS
Descripción:	MCA 224/2018 – Vivienda en calle Boronat, 31-33 en planta segunda, Valls, Tarragona
Inscrita en el Registro de la Propiedad:	Valls, Tarragona, FR 28383, toma 1.852, libro 698, folio 202.
Referencia Catastral:	3317439CF5731E0003YW
Valor de Tasación:	38.518,68 €
Precio mínimo oferta:	30.815 €

EXTERIOR ENTORNO



EXTERIOR FACHADA



EXTERIOR NÚMERO



EXTERIOR – PORTAL Y ZONAS COMUNES



INTERIOR





CROQUIS

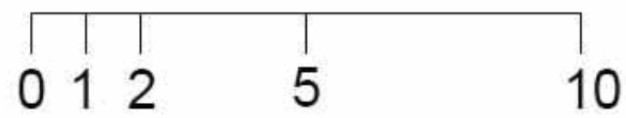

LOTE Nº 5

TITULAR:	ESTADO. DELEGACIÓN DEL GOBIERNO PARA EL PLAN NACIONAL SOBRE DROGAS
Descripción:	Mca 1893/2017 - Plazas de garajes nº 38 y 39 y trasteros nº 36 y 37. Avenida Outeiro, 20-22, planta -2. Edificio Outeiro II. Poio, Pontevedra.
Inscrita en el Registro de la Propiedad:	Nº 2 Pontevedra. FR 10604/G38, inscripción 4ª, tomo 1901, libro 232, folio 84.
Referencia Catastral:	0450006NG2905S0024IK
Valor de Tasación:	18.451,80 €
Precio mínimo oferta:	14.761 €

CROQUIS

PLANTA SÓTANO -2

GARAJES Nº 38/39 y TRASTEROS 36/37

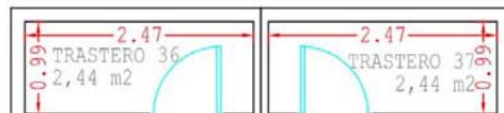

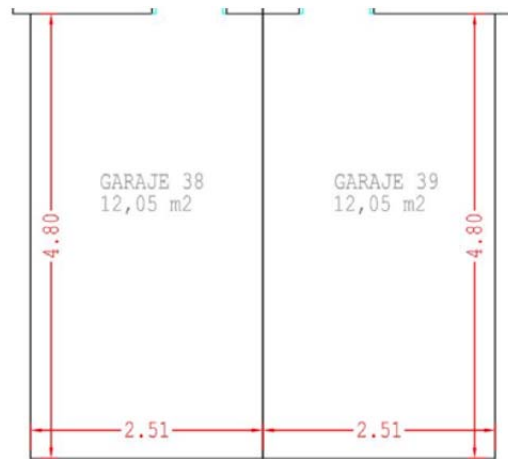

Escala gráfica

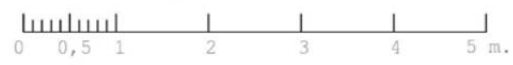

ENTORNO





EDIFICIO



EDIFICIO Nº 22 PORTAL 2



EDIFICIO Nº 20 PORTAL 1



EXTERIOR ACCESO GARAJES



EXTERIOR PORTAL



INTERIOR PORTAL



PLAZAS 38 Y 39



TRASTERO 36



TRASTERO 37



LOTE Nº 6

TITULAR:	ESTADO. DELEGACIÓN DEL GOBIERNO PARA EL PLAN NACIONAL SOBRE DROGAS
Descripción:	Plaza de garaje nº 11, calle Mallorca, 8, planta -1. Cubelles, Barcelona.
Inscrita en el Registro de la Propiedad:	Nº 1 Vilanova i la Geltrú – FR 10114/11, inscripción 4ª, tomo 1879, libro 261, folio 148.
Referencia Catastral:	9220001CF8692S00471A
Valor de Tasación:	11.136 €
Precio mínimo oferta:	8.908 €

CROQUIS

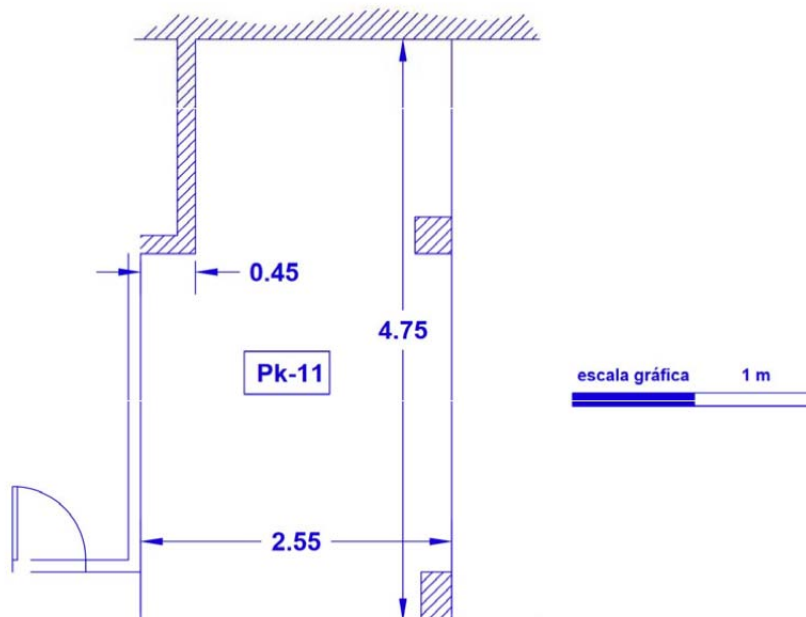

ENTORNO



ENTORNO



EXTERIOR



ACCESO AL APARCAMIENTO



VISTA DEL GARAJE

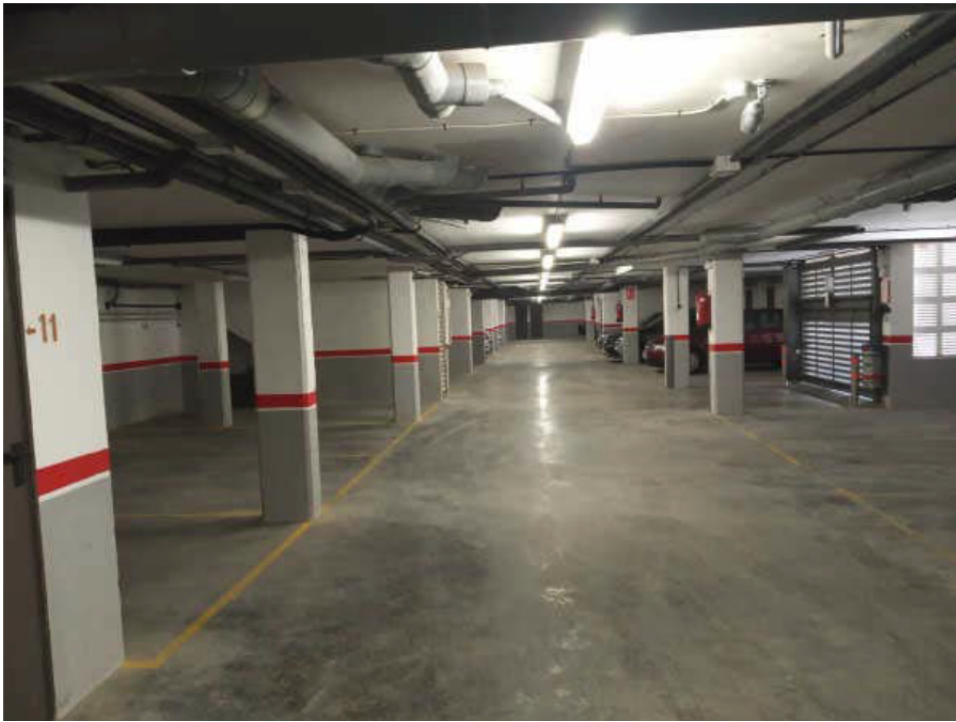

PLAZA

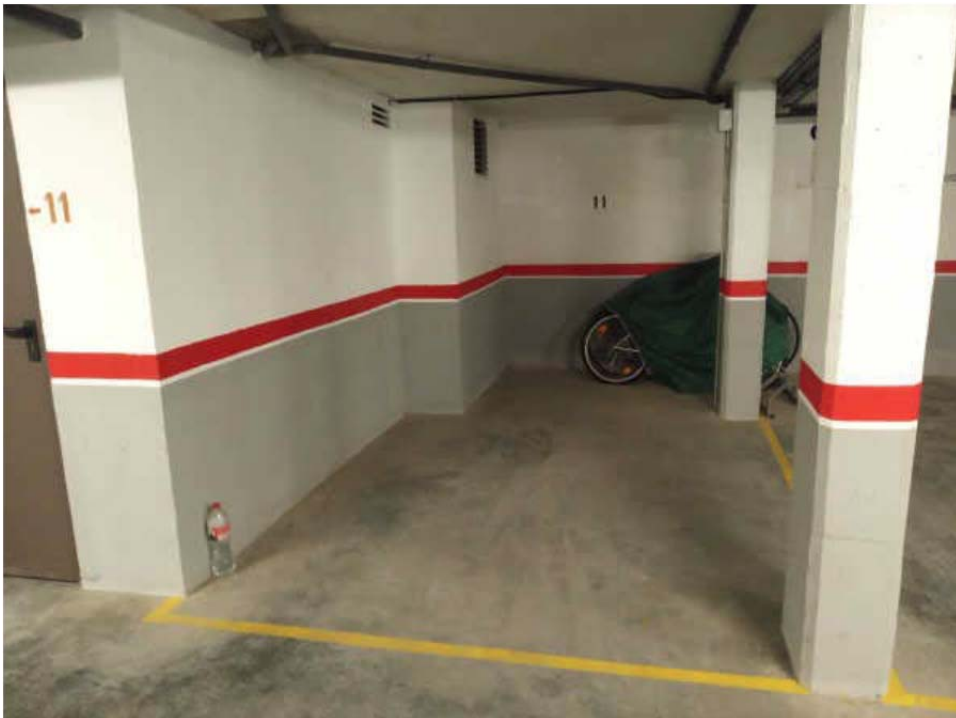

LOTE Nº 7

TITULAR:	ESTADO. DELEGACIÓN DEL GOBIERNO PARA EL PLAN NACIONAL SOBRE DROGAS
Descripción:	MCA 1376/2016 - Finca rústica forestal en el Paraje Pago de la Nava, parcela 105, polígono 11. Laguna de Duero, Valladolid
Inscrita en el Registro de la Propiedad:	Nº 7 Valladolid. FR 7602, inscripción 4ª, libro 100, tomo 674, folio 37
Referencia Catastral:	47077A011001050000UI
Valor de Tasación:	7.044,73 €
Precio mínimo oferta:	5.635,78 €

EMPLAZAMIENTO

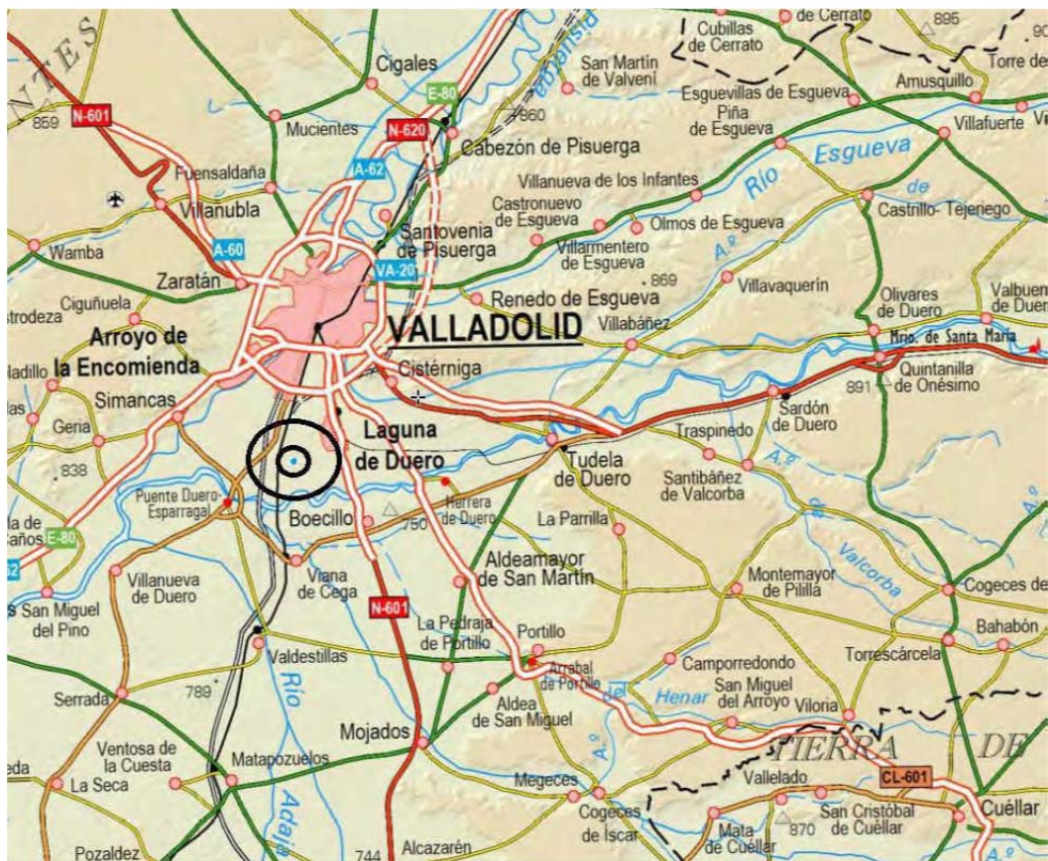

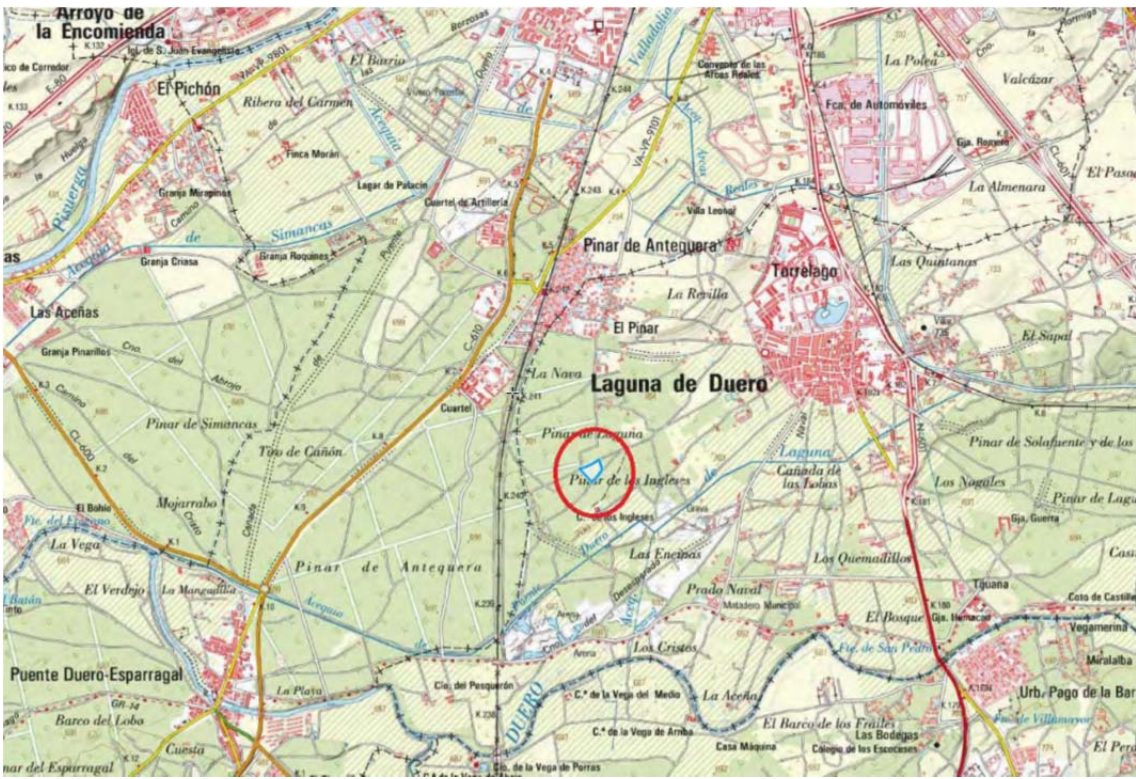

VISTA GENERAL



LOTE Nº 8

TITULAR:	ESTADO. DELEGACIÓN DEL GOBIERNO PARA EL PLAN NACIONAL SOBRE DROGAS
Descripción:	MCA 75/2015 - Plaza de garaje, número 2. Urbanización Jardines de Don Carlos s/n, bloque 1, planta -1. Marbella, Málaga
Inscrita en el Registro de la Propiedad:	Nº 1 Marbella, FR 18249, inscripción 8ª, libro 594, tomo 1729, folio 18
Referencia Catastral:	0801104UF4400S0002YT
Valor de Tasación:	13.445,89 €
Precio mínimo oferta:	10.756 €
Cargas	Sobre la finca se halla pendiente de liquidación a fecha de 23 de marzo de 2021 una deuda hipotecaria (principal, intereses...) que asciende a la cifra de 4.571,26 euros .

CROQUIS

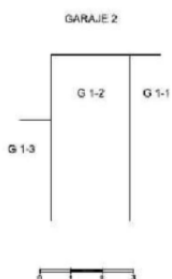

ENTORNO



VIA PRINCIPAL



FACHADA



ENTRADA AL PORTAL



PLAZA DE GARAJE



ZONA DE RODADURA



LOTE Nº 9

TITULAR:	ESTADO. DELEGACIÓN DEL GOBIERNO PARA EL PLAN NACIONAL SOBRE DROGAS
Descripción:	MCA 689/2018 - Amarre nº 13 del pantalán C del puerto deportivo Marina Salinas, Torrevieja, Alicante
Inscrita en el Registro de la Propiedad:	-
Referencia Catastral:	-
Valor de Tasación:	21.564,75 €
Precio mínimo oferta:	17.251,80 €

PLANO AMARRES

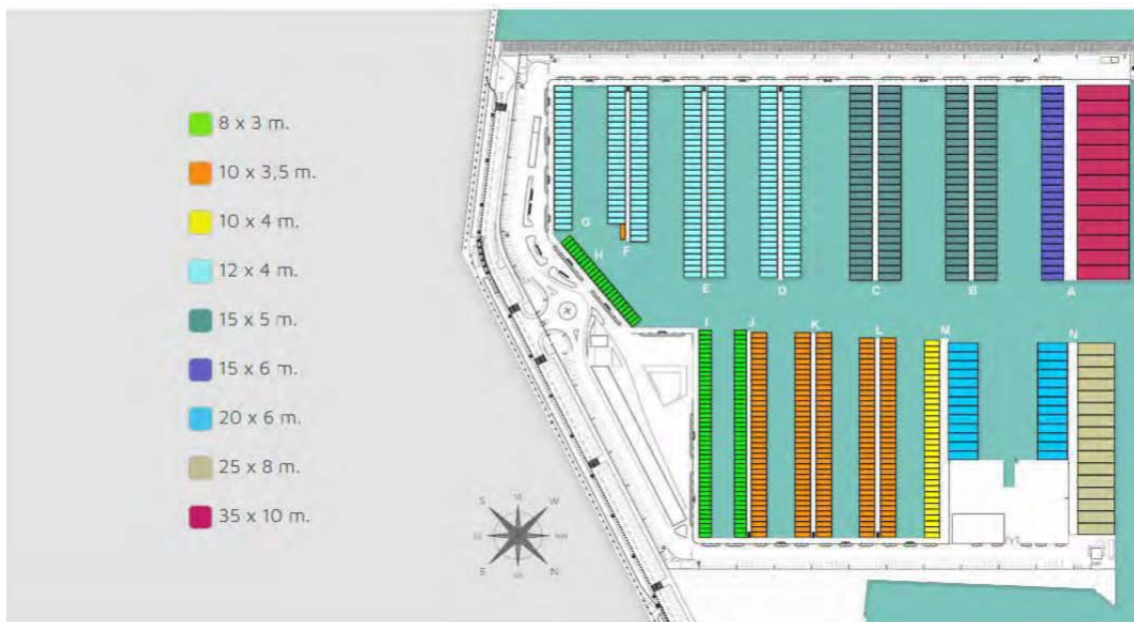



EXTERIOR







ACCESO GENERAL





ACCESO PANTALÁN C-2



LOTE Nº 10

TITULAR:	ESTADO. DELEGACIÓN DEL GOBIERNO PARA EL PLAN NACIONAL SOBRE DROGAS
Descripción:	MCA 124/2009 - Vivienda en lugar Les Teyeras, en Lada, Langreo, Asturias
Inscrita en el Registro de la Propiedad:	Nº 1 de Pola de Laviana. FR 69304, inscripción 3ª, libro 843, tomo 1692, folio 180
Referencia Catastral:	C04700100TN89G0001JL
Valor de Tasación:	5.289,23 €
Precio mínimo oferta:	4.231 €

CROQUIS

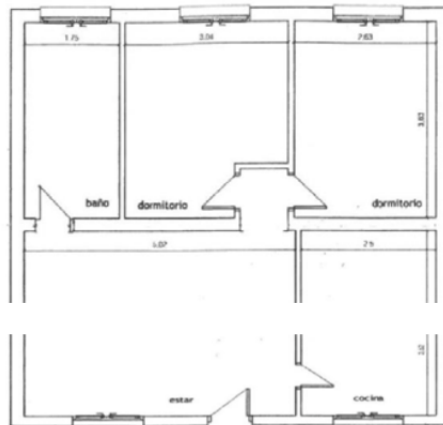

EXP. 481199
\$ 11800

ENTORNO



ACCESO POR FINCA COLINDANTE





FACHADA



INTERIOR





LOTE Nº 11

TITULAR:	ESTADO. DELEGACIÓN DEL GOBIERNO PARA EL PLAN NACIONAL SOBRE DROGAS
Descripción:	MCA 999/2020 - Garaje con trastero nº 158, Avenida del Deporte, s/n. Urbanización Hacienda Golf, manzana D, sótano -1. Isla Cristina, Huelva
Inscrita en el Registro de la Propiedad:	Nº 1 de Lepe. FR 26658, inscripción 4ª, libro 414, tomo 1633, folio 145
Referencia Catastral:	6405408/PB5260N/0050/PM
Valor de Tasación:	8.689,76 €
Precio mínimo oferta:	6.952 €

ENTORNO



FACHADA



ACCESO A LA URBANIZACIÓN

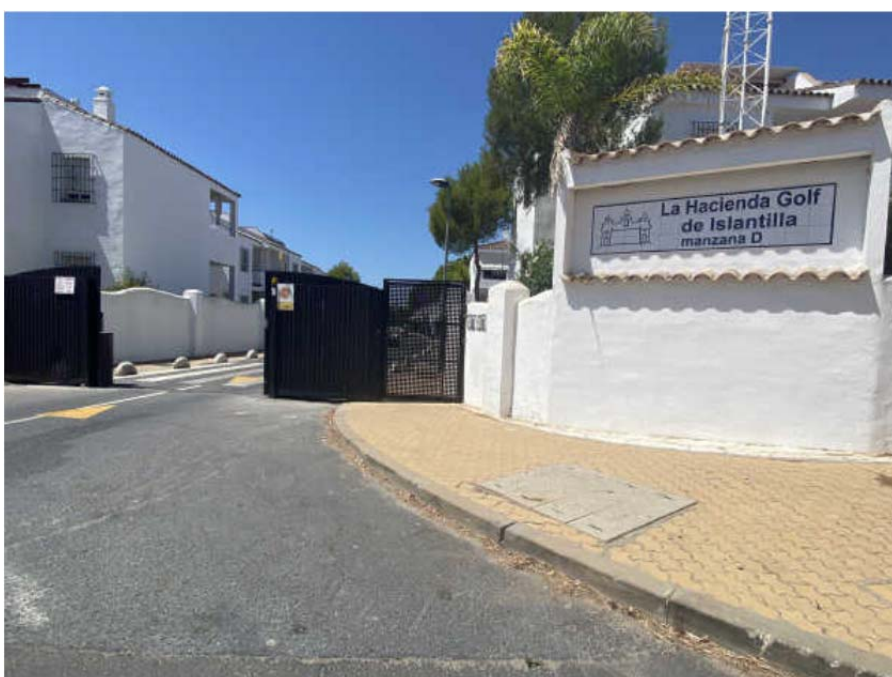

ENTORNO URBANIZACIÓN



GARAJE



TRASTERO



ACCESO AL GARAJE



ENTORNO DEL GARAJE

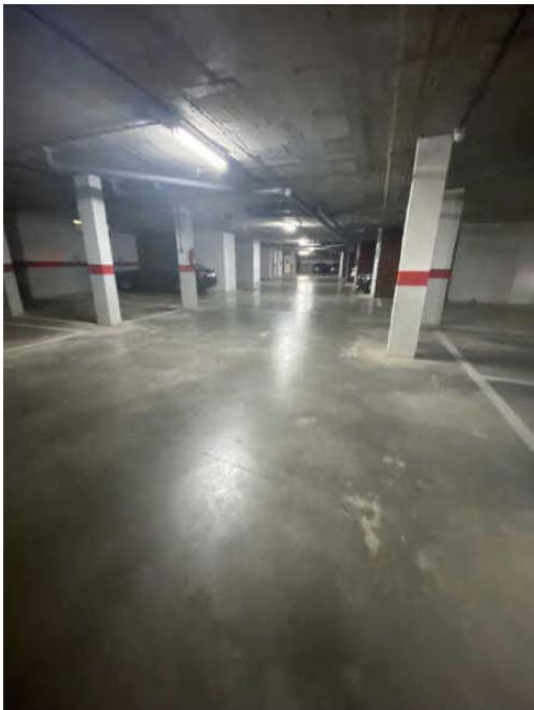

LOTE Nº 12

TITULAR:	ESTADO. DELEGACIÓN DEL GOBIERNO PARA EL PLAN NACIONAL SOBRE DROGAS
Descripción:	MCA 224/2018 - Vivienda unifamiliar entre medianera. Carretera Poblet, 34. L'Espluga de Francolí, Tarragona
Inscrita en el Registro de la Propiedad:	Nº 1 de Montblanc. FR 4245, inscripción 7ª, libro 177, tomo 1335, folio 119
Referencia Catastral:	1546721CF4814E0001ID
Valor de Tasación:	34.340 €
Precio mínimo oferta:	27.472 €

CROQUIS PLANTA BAJA



PL BAJA

0 1 2 3 4 5m
T:100

CROQUIS PLANTA 1ª

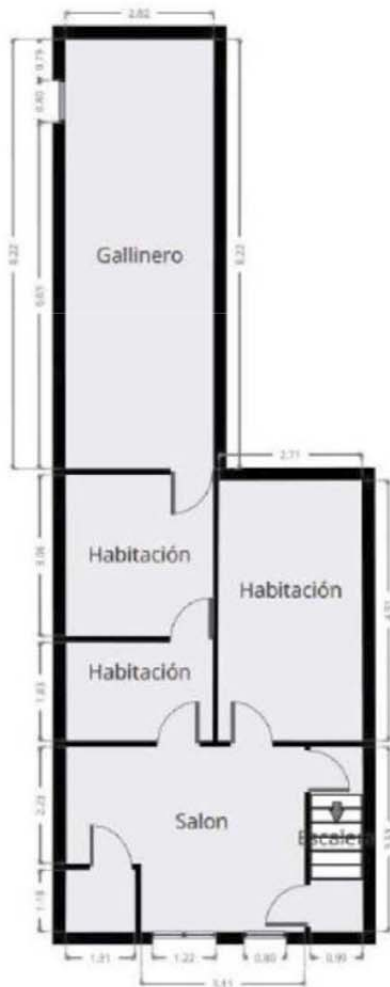

PL. PRIMERA



CROQUIS PLANTA 2ª



PL. SEGUNDA



ENTORNO



FACHADA PRINCIPAL





FACHADA POSTERIOR





FACHADA POSTERIOR

CALLE POSTERIOR





INTERIOR















